

Instructions:

Alaris S2050/2070/2060w/2080w Feed Roller Kit

Translation of these instructions is available at the on-line support page for your scanner model, for instance:

توجد ترجمة لهذه التعليمات على صفحة الدعم المتوفرة عبر الإنترنت والتي تناسب طراز الماسحة الضوئية، على سبيل المثال:

这些说明的译文请参阅扫描仪型号的在线支持网页，例如：

如需這些說明的翻譯，請參見您掃描器型號的線上支援，例如：

La traduction de ces instructions est disponibles sur la page de support en ligne pour votre modèle de scanner, par exemple :

Eine Übersetzung dieser Anweisungen ist auf der Online-Supportseite zu Ihrem Scannermodell verfügbar, wie zum Beispiel:

Una traduzione di queste istruzioni è disponibile presso la nostra pagina di assistenza online per i modelli di scanner:

これらの手順の翻訳は、ご使用のスキナーモデルごとにオンラインサポートページからご利用になれます。例：

해당 스캐너 모델의 온라인 지원에서 이 지침의 번역 내용을 확인할 수 있습니다. 예：

A tradução dessas instruções está disponível na página de suporte on-line para o seu modelo de scanner, por exemplo:

Перевод настоящего руководства доступен на странице онлайн-поддержки для вашей модели сканера, например:

La traducción de estas instrucciones está disponible en la página de asistencia en línea específica para su modelo de escáner, por ejemplo:

Bu talimatların çevirilerine tarayıcınızın modelinin çevrimiçi destek sayfasından ulaşabilirsiniz, örneğin:

www.AlarisWorld.com/go/S2070support

www.AlarisWorld.com/go/S2080wsupport

How to use this kit

Contents

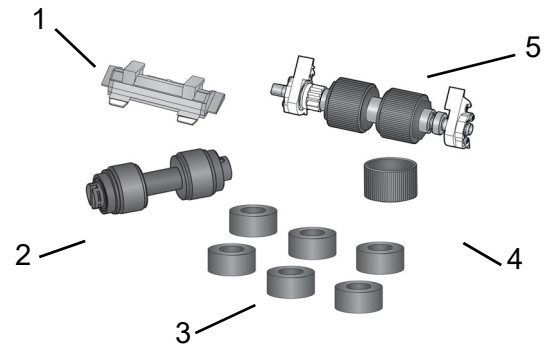

1. One pre-separation pad
2. One separation roller assembly
3. Six separation roller tires (three sets)
4. One urging roller tire
5. One feed roller assembly

Expected use

Replace parts when they are very worn, or when cleaning does not correct page separation or feeding issues.

The recommended order of parts usage is:

1. Replace:
 - Separation roller assembly
 - Pre-separation pad
 - Urging roller tire
 - Feed roller assembly
2. Replace one set of separation roller tires as needed.

Paper scanned, scanner cleaning habits, and other scanner use details may cause you to vary from the above parts replacement.

Before replacing any part

1. Before replacing a part, disconnect the electrical power.
2. Pull the scanner cover release lever to release and open the scanner cover.



out. Discard it.

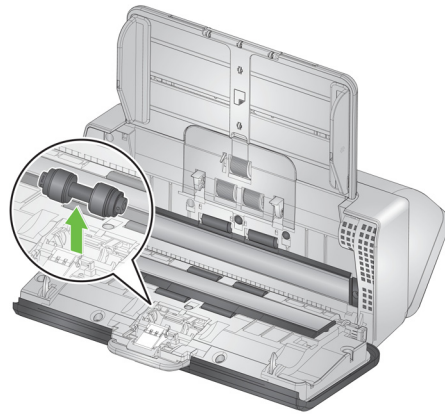

4. Install the new separation roller by aligning the tab with the slot and snapping it into position.



Replacing the separation roller assembly

1. Open the scanner cover.
2. Remove the pre-separation pad by grasping it and pulling it straight out.

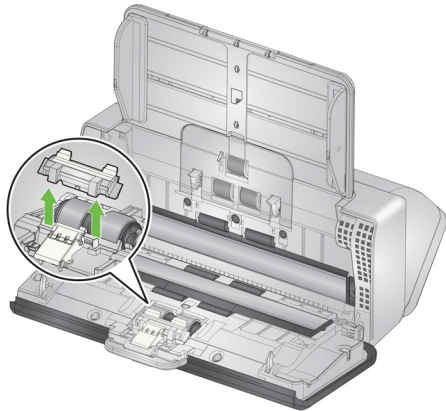

3. Grasp the separation roller and pull it straight

5. Re-install the pre-separation pad (or install a new one) by aligning the slots with the holes on the pre-separation pad and snapping it into place.



6. Close the scanner cover.

Replacing the pre-separation pad

1. Remove the pre-separation pad by grasping it and pulling it out of position.

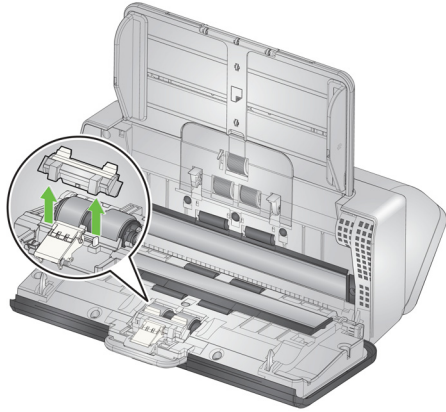

2. Discard the worn pre-separation pad.
3. Install the new pre-separation pad by aligning the slots with the holes on the pre-separation pad and snapping it into place.

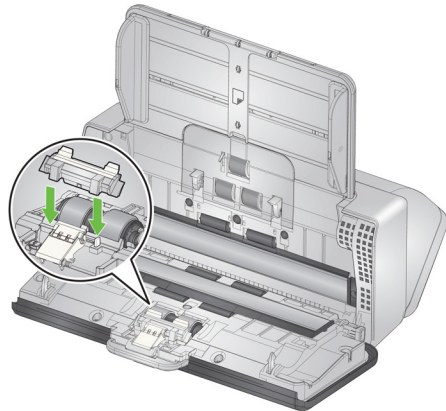

Replacing the urging roller tire

1. Open the scanner cover.
2. Pull on the edge of the feed roller cover and lift

it out of position.

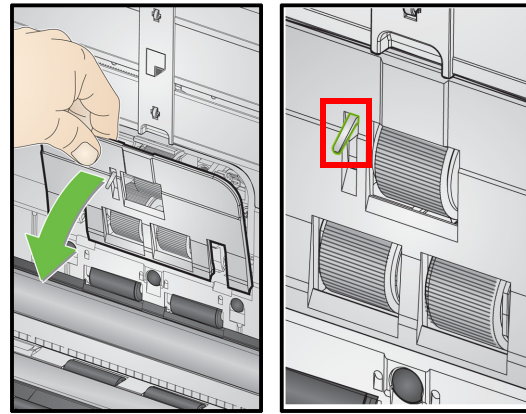

NOTE: Be careful not to damage the paper present sensor.

3. Remove the urging roller.

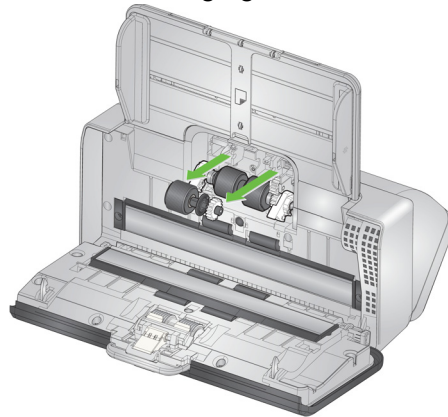

4. Remove the tire from the urging roller. Grasp the tire, lift it over the flange, and pull it off the roller.

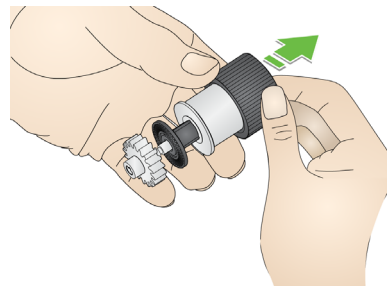

5. Put the new urging roller tire on the urging roller. Use the grooved tire from the consumables kit. Stretch the tire as necessary to pull it over the flange.

IMPORTANT: Do not stretch the tire more than necessary, or the tire may tear.

6. Replace the urging roller, aligning it correctly.

7. Reinstall the feed roller cover by positioning it around the paper present sensor (step 1), aligning the bottom edge of the cover with the scanner (step 2), and pushing it back into position until it snaps into place (step 3).

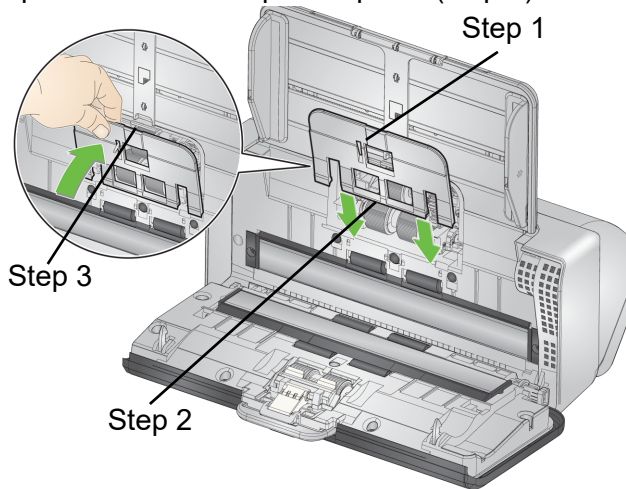

NOTE: Be careful not to damage the paper present sensor.

2. Rotate the feed roller so the pin is aligned with the open slot. The roller rotates in only one direction. Use the white bracket at the end to rotate the roller. When the pin is aligned properly, lift the roller out of position.

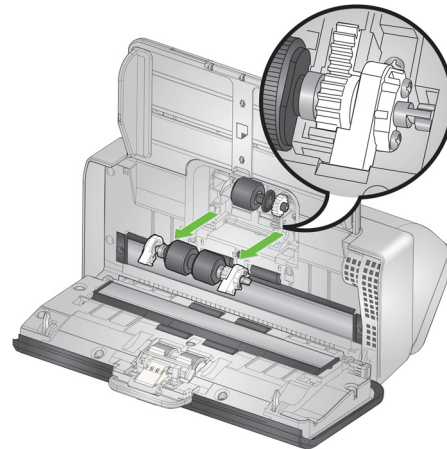

Replacing the feed roller assembly

An animation of this process is available at our on-line support for your scanner model, for instance:

www.AlarisWorld.com/go/S2070support

www.AlarisWorld.com/go/S2080wsupport

1. Pull on the edge of the feed roller cover and lift it out of position.

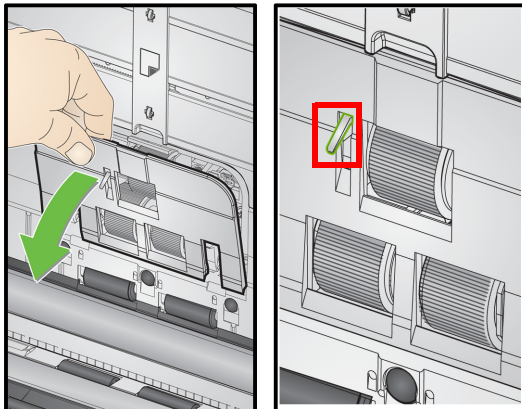

3. Discard the worn feed roller.
4. Install the new feed roller: align the pins with the open slots and fit the roller into position. Be sure the gears and brackets are aligned and the roller snaps into place.

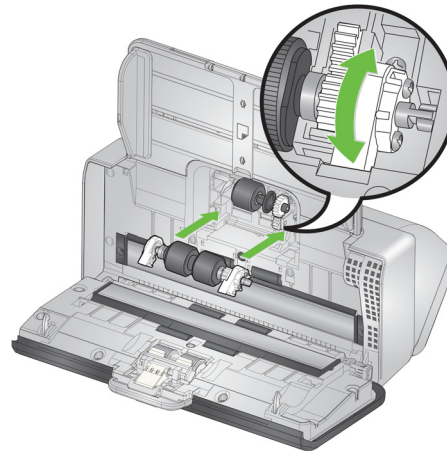

- Reinstall the feed roller cover by positioning it around the paper present sensor, aligning the bottom edge of the cover with the scanner, and pushing it back into position until it snaps into place.

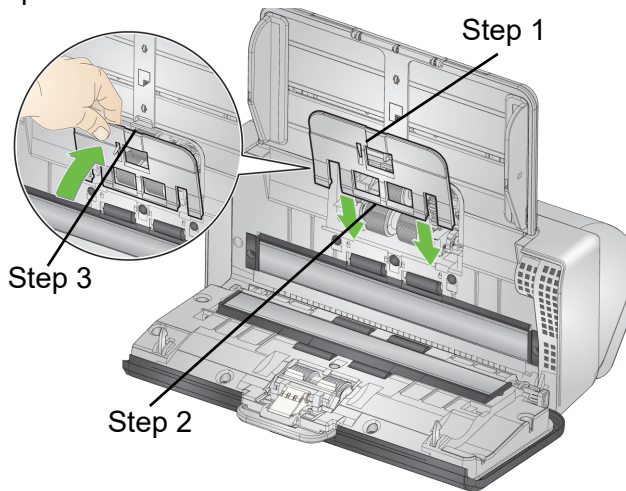

Replacing the separation roller tires

- Remove the pre-separation pad by grasping it and pulling it straight out.

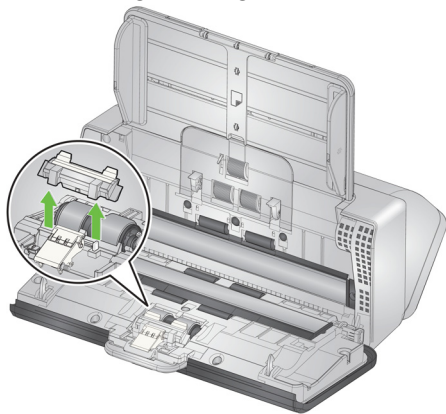

- Grasp the separation roller and pull it straight

out.

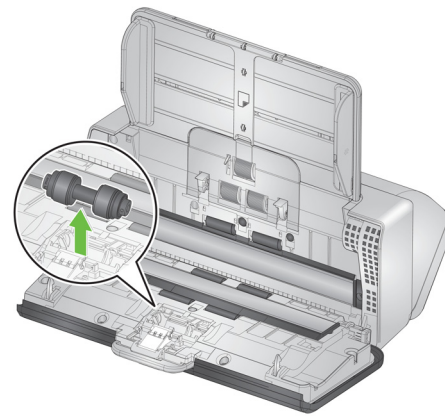

- Remove the tires from the separation roller. Grasp one of the tires, lift it over the flange, and pull it off the roller. Repeat for the other tire.
- Put new tires on the separation roller. Use the smooth tires from the consumables kit. Stretch the tire as necessary to pull it over the flange.

IMPORTANT: Do not stretch the tire more than necessary, or the tire may tear.



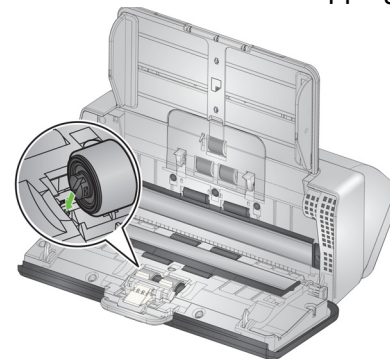

- Install the new separation roller by aligning the tab with the slot and snapping it into position.



-
6. Re-install the pre-separation pad by aligning the slots with the holes on the pre-separation pad and snapping it into place.



When you have replaced a part

1. Close the scanner cover.
2. Plug the scanner in and turn the power on.
3. Clean:
 - Imaging path
 - Transport rollers
 - Any parts you did not replace(Refer to chapter 4 Maintenance in the *Alaris S2000/S2000w Scanners: User's Guide* for cleaning procedures.)
4. Choose Maintenance at the scanner screen. Then go to the **Meters** display. Choose **Reset**  for *Clean*.
5. If you replace the roller assemblies and the separation pad, at the **Meters** display you should also choose **Reset**  for the *Feed kit*.
6. Wash your hands with soap and water after replacing any parts.



5K7604